



ComplianceSigns.com

Resource Guide

CAUTION

NO

TRESPASSING



Table of Contents

<u>Welcome:</u>	01
Introduction.....	01
About Compliance Signs, Inc.....	02
<u>Product Data Bulletins:</u>	03
2D Projection Signs- View 2 Sides	03
3D Triangle Signs, Multi Angle Viewable	04
ADA Braille Signs	05
ADA Signs-California Door Symbols	10
ADA Signs-Door Symbols	11
Aluminum Signs.....	12
Anti-Graffiti.....	13
Car Topper.....	14
Ceiling Mount Signs-Viewable 2 Sides	15
Certificate Frame.....	16
Clear Labels & Stickers	17
Clear Window Cling	18
Dry Erase.....	19
Engraved Signs	20
Fence EasyMount	21
Glow-in-the-Dark	22
Magnetic	23
Mounting Accessories	24
Parking Control Signs	28
Pipe Wrap	29
Poly Film	30
PVC Plastic Signs	31
PVC Tag.....	32
Reflective.....	33
Self Adhesive Labels & Stickers	34
Sign Frame	35
Sign Plaque	36
Sliding Engraved Signs	37
Stencil	38
Sublimation Process and Materials	39
Tape	40
<u>Restroom Product Group-Offering Summary:</u>	41
<u>Terms and Conditions:</u>	45
Orders.....	46
Payment Terms	47
Shipment.....	48
Return Policy.....	49
Warranty and Compliance Guarantee.....	50



Welcome

Introduction

Welcome to ComplianceSigns.com

Thank you for your interest in ComplianceSigns.com. This booklet will answer questions you may have about our company, how our products are made, our guarantee, return policies and more. It will help you understand what we have to offer, but it's not a product catalog. There's simply no way we could produce a catalog that would keep up with our ever-changing selection of signs and labels.

We constantly monitor new workplace safety rules and regulations to make correct signage available to meet your needs -- and every month you'll find dozens of new signs at ComplianceSigns.com. We always have new products in development, and continually refine our website store to improve your ordering experience.

The following pages will answer many of your questions about our products, from explaining our extensive restroom sign offering, to our Compliance Guarantee, to the hole size on our parking signs. But if you have any additional questions or need a custom sign or label, please contact our friendly sales staff at 1-800-578-1245. They're always glad to help.

Paul Sandefer
President, Compliance Signs, Inc.



Welcome

About Compliance Signs, Inc.

Who We Are



ComplianceSigns.com is among the nation's leading suppliers of OSHA- and ANSI-compliant signs and labels. We manufacture all our signs and labels at our plant in Chadwick, Illinois, and sell them exclusively through our website, www.ComplianceSigns.com. Since 2005, businesses, government and military agencies, schools, health care facilities and many others have used our website to find the best selection and value in safety signs and labels. In August, 2010, ComplianceSigns.com was named one of America's fastest-growing private companies and placed on the Inc. 5000 list.

ComplianceSigns.com is owned by Compliance Signs, Inc., which also owns Special Signs and Symbols Company (SSSCO). SSSCO has served the special signage needs of the elevator and escalator industries since 1975, and can be found on the web at www.SSSCO.com.

Who We Serve



Today, our clients span a wide range of industries and public agencies that depend on well-designed signs and labels to protect their employees and customers: military and government agencies, industrial and chemical manufacturers, retailers, schools, physician offices and health care facilities, professional buildings, churches and many others.

What We Believe



Shopping for workplace signs and decals shouldn't be an ordeal. And, finding exactly what you need should be a fast, easy experience. That's why we designed an online store that lets you easily search and shop more than 60,000 products from the convenience of your computer. And our unique custom sign generators let you create custom signs quickly and easily.

What We Promise



We promise you'll never pay less for top-quality signs and labels. We want our customers to be more than just satisfied -- that's why your satisfaction is guaranteed. From our great customer service team to flexible and secure payment options to our famous fast delivery, we look forward to earning your business.

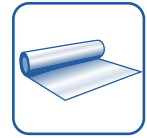

2D Projection Signs – View 2 Sides

Product Data Bulletin

Description:

Aluminum substrate signs printed with UV resistant eco-solvent ink, reinforced with UV, chemical, abrasion, and moisture resistant laminate layer. One inch flange is shaped to allow protrusion mounting on a vertical surface. Recommended for indoor and outdoor business and industrial environments. Service temperature range -40 to +176 F.

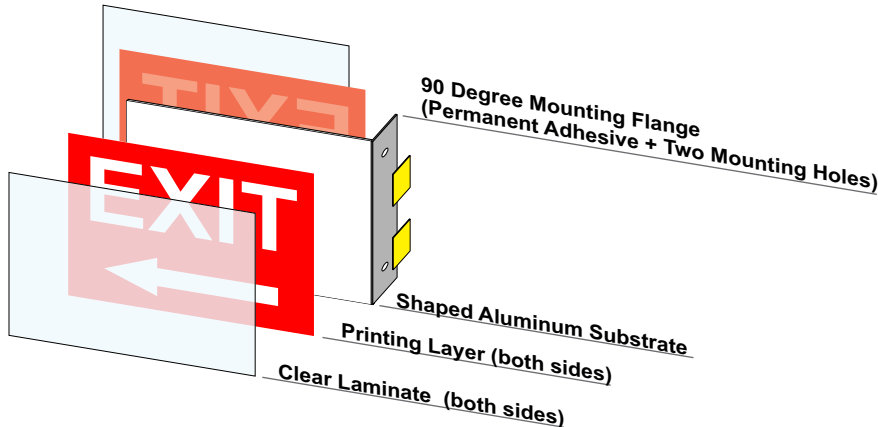

FRONT



REAR

Specifications:

SUBSTRATE:	0.040" (1mm) aluminum, white enamel coated both sides
PRINTING LAYER:	4.0 mm Vinyl with permanent acrylic adhesive UV Stable Eco-solvent ink
LAMINATE:	2.5 mil, PVC Film (Optically Clear) <ul style="list-style-type: none"> • Scratch Resistant • Chemical Resistant • UV Resistant
MOUNTING:	Two strips of 1/2" double-sided foam tape + Two 0.20" Holes for Screw Mount on shaped flange
CORNERS:	0.25" Radius Corners
OPTIONS:	Available for additional charge: <ul style="list-style-type: none"> • Reflective or Glow-in-the-Dark

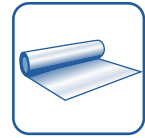

3D Triangle Signs, Multi Angle Viewable

Product Data Bulletin

Description:

Aluminum substrate signs printed with UV resistant eco-solvent ink, reinforced with UV, chemical, abrasion, and moisture resistant laminate layer. One inch flanges are shaped to allow protrusion mounting on a vertical surface. Recommended for indoor and outdoor business and industrial environments. Service temperature range -40 to +176 F.

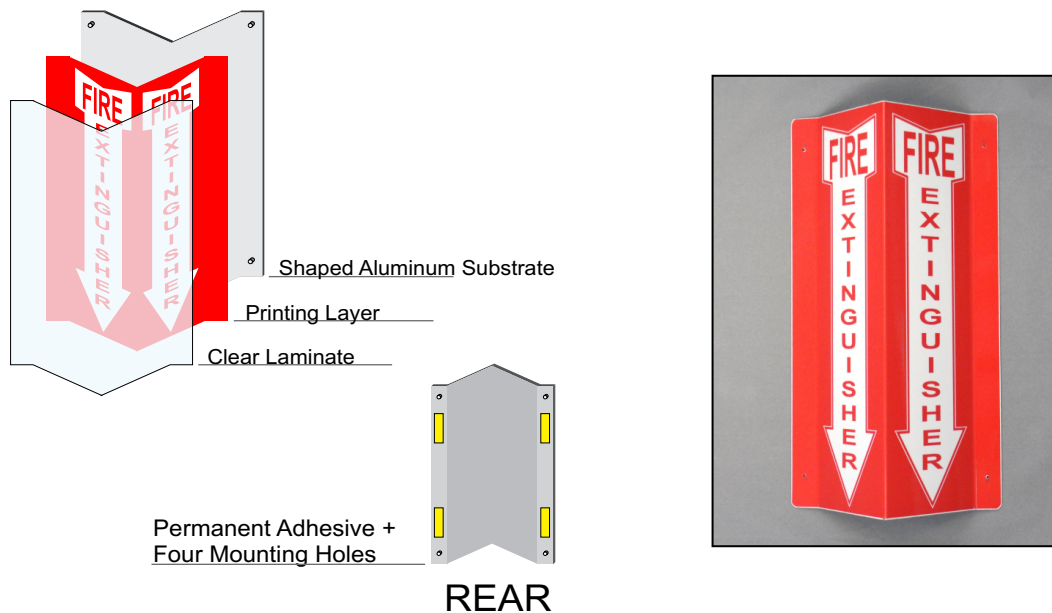

Specifications:

SUBSTRATE:	0.040" (1mm) aluminum, white enamel coated both sides
PRINTING LAYER:	4.0 mil Vinyl with permanent acrylic adhesive UV Stable Eco-solvent ink
LAMINATE:	2.5 mil, PVC Film (Optically Clear) <ul style="list-style-type: none"> • Scratch Resistant • Chemical Resistant • UV Resistant
MOUNTING:	Two Flanges each with: Four strips of 1/2" double-sided foam tape + Two, 0.20" Holes for Screw Mounting
CORNERS:	0.25" Radius Corners
OPTIONS:	Reflective or Glow-in-the-Dark are available for additional charge.

ADA Braille Signs

Product Data Bulletin

Description:

Acrylic tactile signs designed to meet federal ADA / ADAAG guidelines for content, symbol design, Braille translation, non-glare finish and color contrast levels. Available in a wide range of colors for any decor.

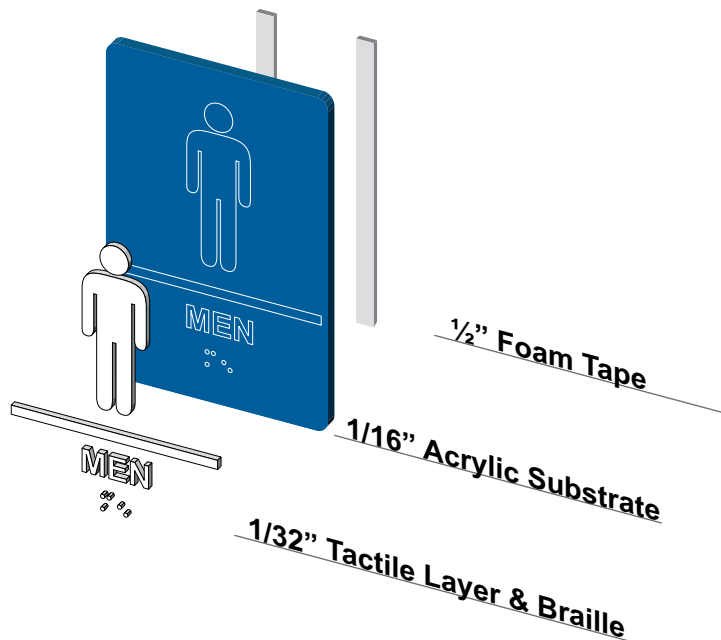

Specifications:

TACTILE LAYER:	1/32" Tactile symbols and wording / English Grade 2 Braille <i>Optional Spanish with full character set Braille</i>
SUBSTRATE:	1/16" Laminated impact acrylic Matte finish for better visibility for the visually impaired
MOUNTING:	Two strips of 1/2" double-sided foam tape.
OPTIONS:	Available for additional charge: <ul style="list-style-type: none">• Custom architectural colors• Custom / branded logos and wording• Custom sizes

ADA Braille Signs

Product Data Bulletin

Description:

Acrylic tactile signs designed to meet federal ADA / ADAAG guidelines for content, symbol design, Braille translation, non-glare finish and color contrast levels. Available in a wide range of colors for any decor.



Specifications:

A	PICTOGRAM FIELD	Field height of 6 inches (150 mm) minimum Characters and braille are not located in the pictogram field
B	CHARACTER ELEMENT	Characters separated a minimum of 3/8 inches (9.53 mm) from raised borders or decorative elements
C	CHARACTER HEIGHT	Measures vertically from the baseline of the character is 5/8 inches (15.88 mm) minimum
D	BRAILLE POSITION	Separated 3/8 inches (9.53 mm) minimum from Characters and Borders
E	BRAILLE	Grade 2 Braille, meets Dimension and Capitalization requirements of ADA Standards for Accessible Design

ADA Braille Signs

Product Data Bulletin

Description:

Acrylic tactile signs designed to meet federal ADA / ADAAG guidelines for content, symbol design, braille translation, non-glare finish and color contrast levels. Available in a wide range of colors for any decor.



Specifications:

A	PICTOGRAM FIELD	Field height of 6 inches (150 mm) minimum Characters and braille are not located in the pictogram field
B	CHARACTER ELEMENT	Characters separated a minimum of 3/8 inches (9.53 mm) from raised borders or decorative elements
C	CHARACTER HEIGHT	Measures vertically from the baseline of the character is 5/8 inches (15.88 mm) minimum
D	LINE SPACING	Spacing between the baselines of separate lines of characters within a message are 135% minimum and 170% maximum of the character height (0.22 inches minimum)
E	BRAILLE POSITION	Separated 3/8 inches (9.53 mm) minimum from Characters and Borders
F	BRAILLE	Grade 2 Braille, meets Dimension and Capitalization requirements of ADA Standards for Accessible Design

ADA Braille Signs

Product Data Bulletin

Description:

Acrylic tactile signs designed to meet federal ADA / ADAAG guidelines for content, symbol design, braille translation, non-glare finish and color contrast levels. Available in a wide range of colors for any decor.

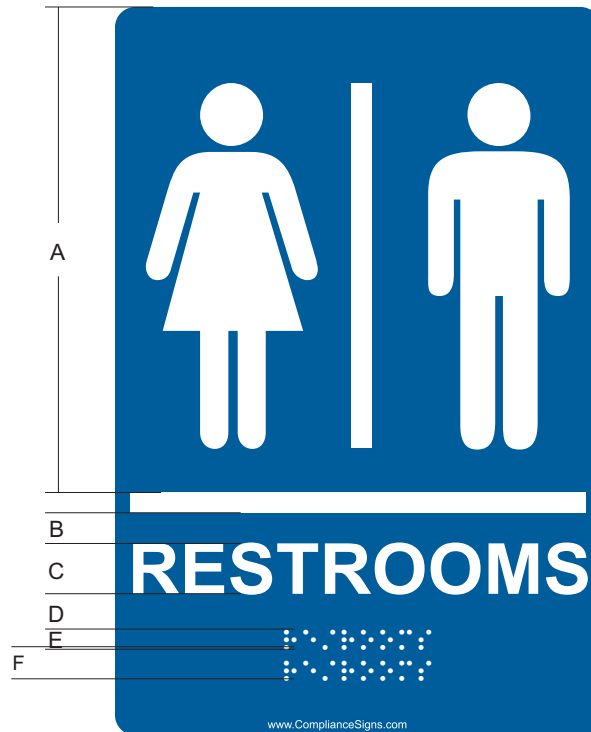

Specifications:

A	PICTOGRAM FIELD	Field height of 6 inches (150 mm) minimum Characters and braille are not located in the pictogram field
B	CHARACTER ELEMENT	Characters separated a minimum of 3/8 inches (9.53 mm) from raised borders or decorative elements
C	CHARACTER HEIGHT	Measures vertically from the baseline of the character is 5/8 inches (15.88 mm) minimum
D	BRAILLE POSITION	Separated 3/8 inches (9.53 mm) minimum from Characters and Borders
E	BRAILLE	Grade 2 Braille, meets Dimension and Capitalization requirements of ADA Standards for Accessible Design
F	BRAILLE DIMENSIONS	Distance between corresponding dots from one cell directly below is 0.4 inches (10.16 mm) maximum

ADA Braille Signs

Product Data Bulletin

Description:

Acrylic tactile signs designed to meet federal ADA / ADAAG guidelines for content, symbol design, braille translation, non-glare finish and color contrast levels. Available in a wide range of colors for any decor.



Specifications:

A	CHARACTER HEIGHT	Measures vertically from the baseline of the character is 5/8 inches (15.88 mm) minimum
B	BRAILLE POSITION	Separated 3/8 inches (9.53 mm) minimum from Characters and Borders
C	BRAILLE	Grade 2 Braille, meets Dimension and Capitalization requirements of ADA Standards for Accessible Design

ADA Signs – California Door Symbols

Product Data Bulletin

Description:

Cast acrylic signs designed to meet California's strict Title 24 / Section 1115B.6 Identification symbols for signs shape and thickness, symbol design, and gloss and color contrast levels. Material thickness and unique, rich colors complement the most demanding decorating requirements. To meet California Title 24 requirements, please purchase a Title 24 set which includes an ADA Restroom Sign and a Door Symbol.

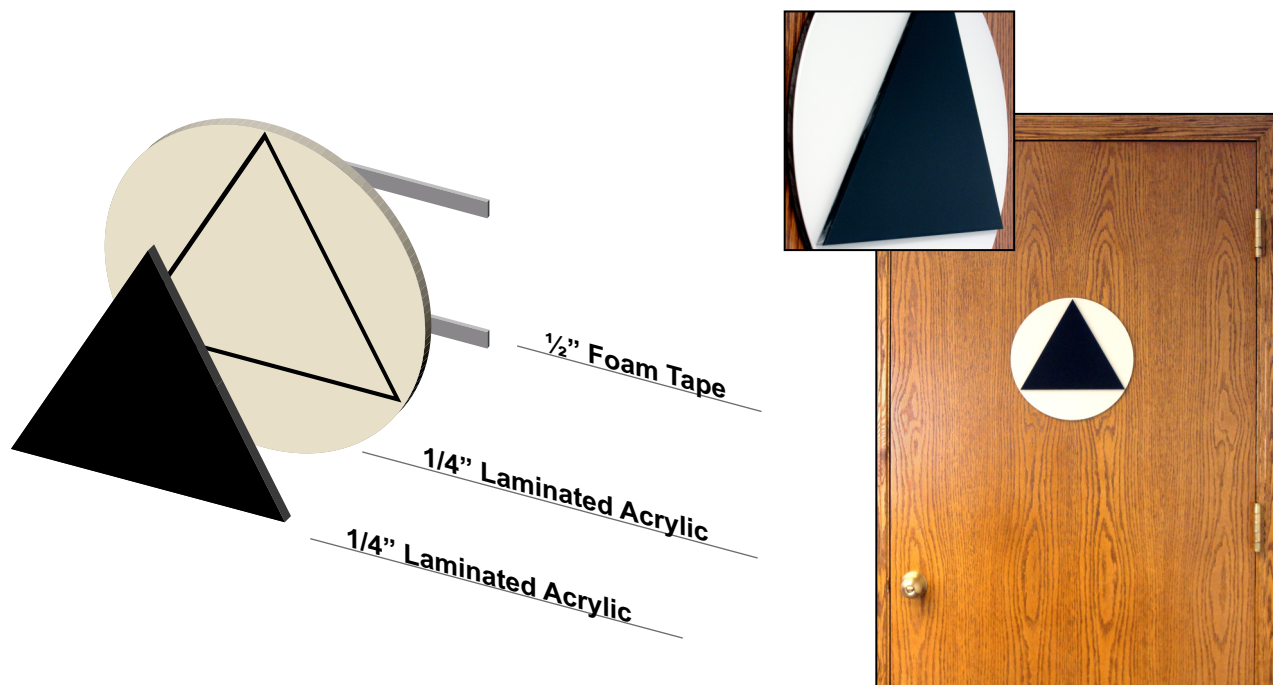

Specifications:

- SUBSTRATE:** 1/4" ADA Color Cast Laminated Acrylic, Premium Material
(A second 1/4" layer is provided for Unisex signs)
Matte finish provides better visibility for the visually impaired
- MOUNTING:** Two strips of 1/2" double-sided foam tape
- OPTIONS:** Available for additional charge:
- Custom architectural colors
 - Custom / branded logos and wording
 - Custom sizes

ADA Signs – Door Symbols

Product Data Bulletin

Description:

Cast Acrylic signs designed for the door. Material thickness and unique, rich colors complement the most demanding decorating requirements.

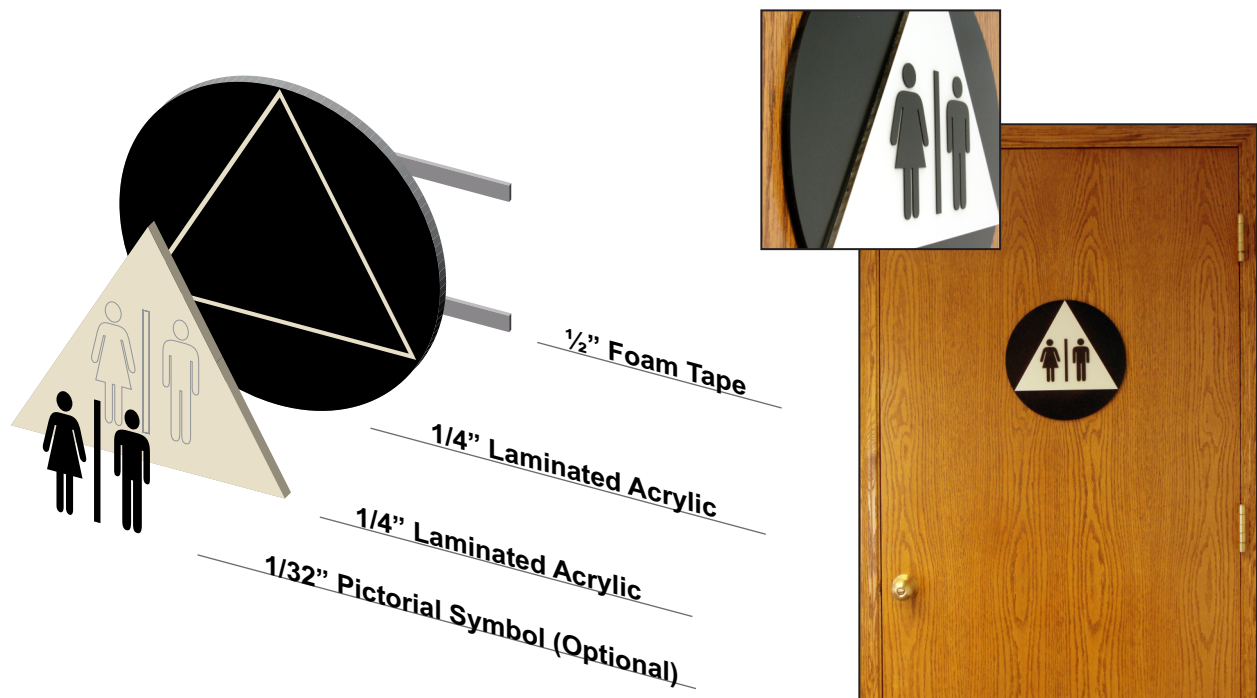

Specifications:

PICTORIAL SYMBOL:	1/32 " Thick, 6" height pictorial symbol (Optional - some California municipalities discourage a tactile layer.)
SUBSTRATE:	1/4" ADA Color Cast Laminated Acrylic, Premium Material (A second 1/4" layer is provided for Unisex signs) Matte finish provides better visibility for the visually impaired
MOUNTING:	Two strips of 1/2" double-sided foam tape
OPTIONS:	Available for additional charge: <ul style="list-style-type: none">• Custom architectural colors• Custom / branded logos and wording• Custom sizes

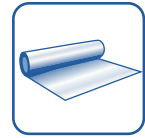

Aluminum Signs

Product Data Bulletin

Description:

Aluminum substrate signs printed with UV resistant eco-solvent ink, reinforced with UV, chemical, abrasion, and moisture resistant laminate layer. Recommended for indoor and outdoor business and industrial environments. Service temperature range -40 F to +176 F.

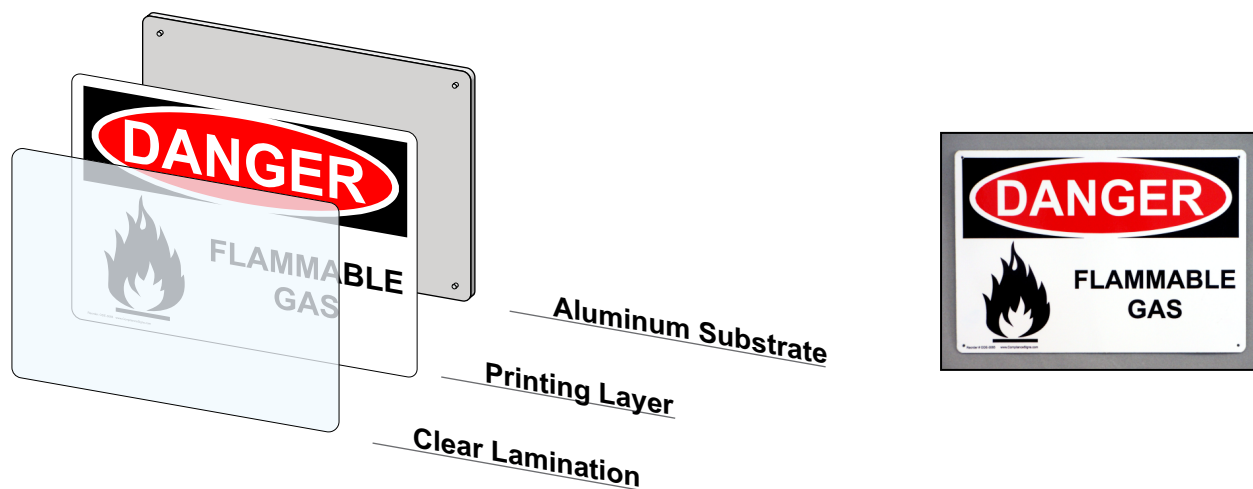

Specifications:

SUBSTRATE:	0.040" (1mm) aluminum, white enamel coated both sides
PRINTING LAYER:	4.0 mil Vinyl with permanent acrylic adhesive UV Stable Eco-solvent ink
LAMINATE:	2.5 mil, PVC Film (Optically Clear) <ul style="list-style-type: none"> • Scratch Resistant • Chemical Resistant • UV Resistant
MOUNTING:	0.20" diameter holes in each of 4 corners Holes offset 0.25" from adjacent edges Mounting hardware not included
CORNERS:	0.25" Radius Corners
OPTIONS:	Available for additional charge: <ul style="list-style-type: none"> • Adhesive backing with or without holes • Reflective or Glow-in-the-Dark • Anti-graffiti and Anti-skid/Floor laminate options.

Anti-Graffiti Laminate

Product Data Bulletin

Description:

Vinyl, clear, or reflective printing layer is laminated with a clear anti-graffiti laminate. The laminate is designed to provide resistance to chemicals and graffiti with long term durability. It has a chemical resistance in distilled water, Detergent, 10% Ammonium Hydroxide, Gasoline, and 10% HCl.

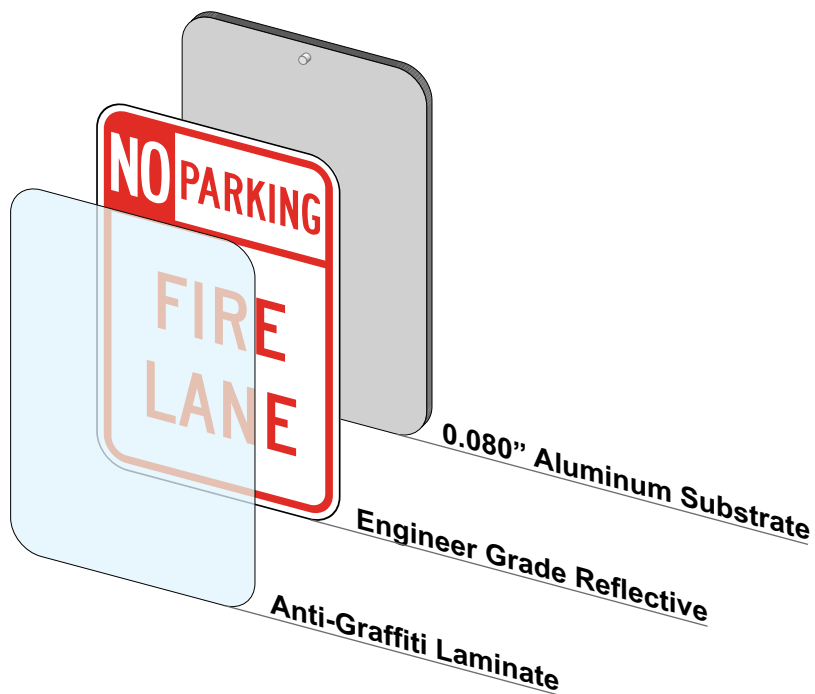

Specifications:

ANTI-GRAFFITI LAMINATE:

- 1.0 mil, Permanent/Clear Gloss- Acrylic
- Scratch Resistant
- Chemical Resistant
- UV Resistant

Car Toppers

Product Data Bulletin

Description:

Corrugated Plastic Toppers are made from Coroplast, a high-quality polypropylene twin-wall profile sheet, making them lighter in weight and easy to transport. Copolymer resin is used to help increase impact and low temperature performance. Copolymer resin is also used to maintain the ability for the sheets to be flexed an unlimited number of times without breaking. The four powerful magnets that are included are tested at speeds up to 65 MPH. You should not use the car topper in severe weather.

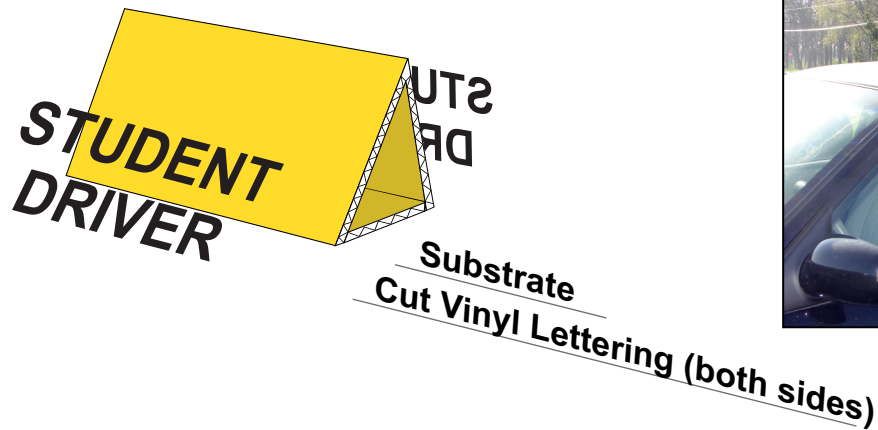

Specifications:

SUBSTRATE:	4.0 mil Corrugated Plastic coroplast
CUT VINYL LETTERING:	2.75 mil Vinyl with solvent-based adhesive
MOUNTING:	4 High Strength magnets <ul style="list-style-type: none">• Tested up to 65 mph

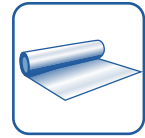

Ceiling Mount Signs – Viewable 2 Sides

Product Data Bulletin

Description:

Aluminum substrate signs printed with UV resistant eco-solvent ink, reinforced with UV, chemical, abrasion, and moisture resistant laminate layer. Double flange is shaped to allow mounting on a drop ceiling by setting the sign between the ceiling tile and the tile track. Recommended for indoor and outdoor business and industrial environments. Service temperature range -40 to +176 F.

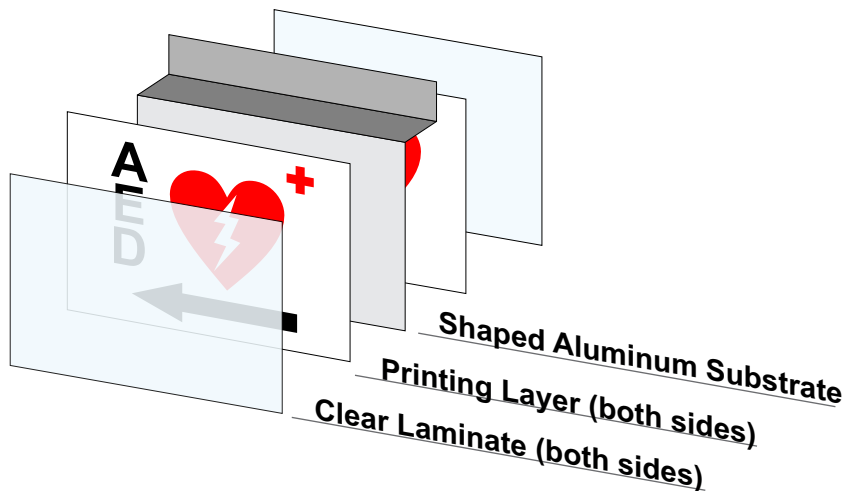

FRONT



REAR

Specifications:

SUBSTRATE:	0.040" (1mm) aluminum, white enamel coated both sides
PRINTING LAYER:	4.0 mil Vinyl with permanent acrylic adhesive UV Stable Eco-solvent ink
LAMINATE:	2.5 mil, PVC Film (Optically Clear) <ul style="list-style-type: none"> • Scratch Resistant • Chemical Resistant • UV Resistant
MOUNTING:	Double shaped flange for mounting on drop ceiling 0.25" Radius on Corners
OPTIONS:	Available for additional charge: <ul style="list-style-type: none"> • Reflective or Glow-in-the-Dark

Certificate Frame

Product Data Bulletin

Description:

Extruded aluminum frames with acrylic lens are suitable for posting of certificates and other notices. The open slot in the back allows the certificate to be changed as needed. Certificate frames come in standard sizes and can be customized as needed

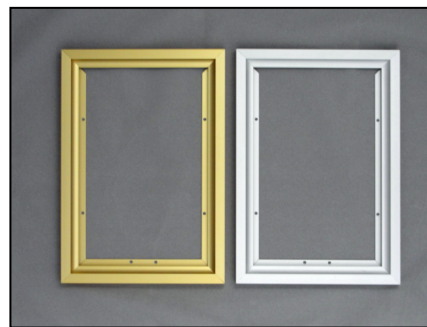
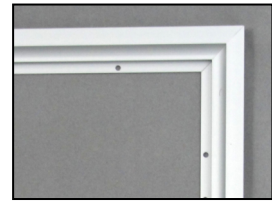

Specifications:

- FRAME MATERIAL:** Extruded aluminum frame with brushed aluminum or brass like finish. Lens is optically clear, impact resistant acrylic.
- MOUNTING:** Frames can be mounted with screws or foam backed permanent adhesive tape (not included).
- OPTIONS:** Other sizes and finishes available upon request

Clear Labels & Stickers

Product Data Bulletin

Description:

Clear, self adhesive vinyl labels printed with UV resistant eco-solvent ink. Clear labels can be printed to be read from the front (standard mount), or through a mounting surface such as mounting to the back of a glass door (reverse mount). Recommended for indoor and outdoor business and industrial environments. Service temperature range -40 F to +180 F.



Specifications:

- PRINTING LAYER:** 3.4 mil PVC clear film printed with UV Stable Eco-solvent ink
- LAMINATE:** 2.5 mil, PVC Film (Optically Clear)
- Scratch Resistant
 - Chemical Resistant
 - UV Resistant
- MOUNTING:** 0.9 mil, clear permanent acrylic adhesive / 6.7 mil easily removed backing liner.
- Adhesive on Back / Forward Printed
- Adhesive on Front / Reverse Printed - Read through a clear mounting surface such as a glass door or window.
- OPTIONS:** Special package and precut sheet quantities

Clear Window Cling

Product Data Bulletin

Description:

Clear, vinyl labels printed with UV resistant eco-solvent ink. Clear labels can be printed to be read from the front (standard mount), or through a mounting surface such as mounting to the back of a glass door (reverse mount). Recommended for indoor and outdoor business and industrial environments. Service temperature range -20 F to +200 F.



Picture taken from outside

Clear Window Cling

Clear Window Cling Standard Mount



Picture taken from inside

Clear Window Cling

Clear Window Cling Reverse Mount

Specifications:

PRINTING LAYER: 7.0 mil premium clear film printed with UV Stable Eco-solvent ink

OPTIONS: Special package and precut sheet quantities

Dry Erase

Product Data Bulletin

Description:

Aluminum substrate signs printed with UV resistant eco-solvent ink. Lamination formulated for use with “dry erase” is applied over the printing layer, allowing users to quickly and easily update sign content. Recommended for indoor business and industrial environments. Service temperatures -40 F to +176 F.

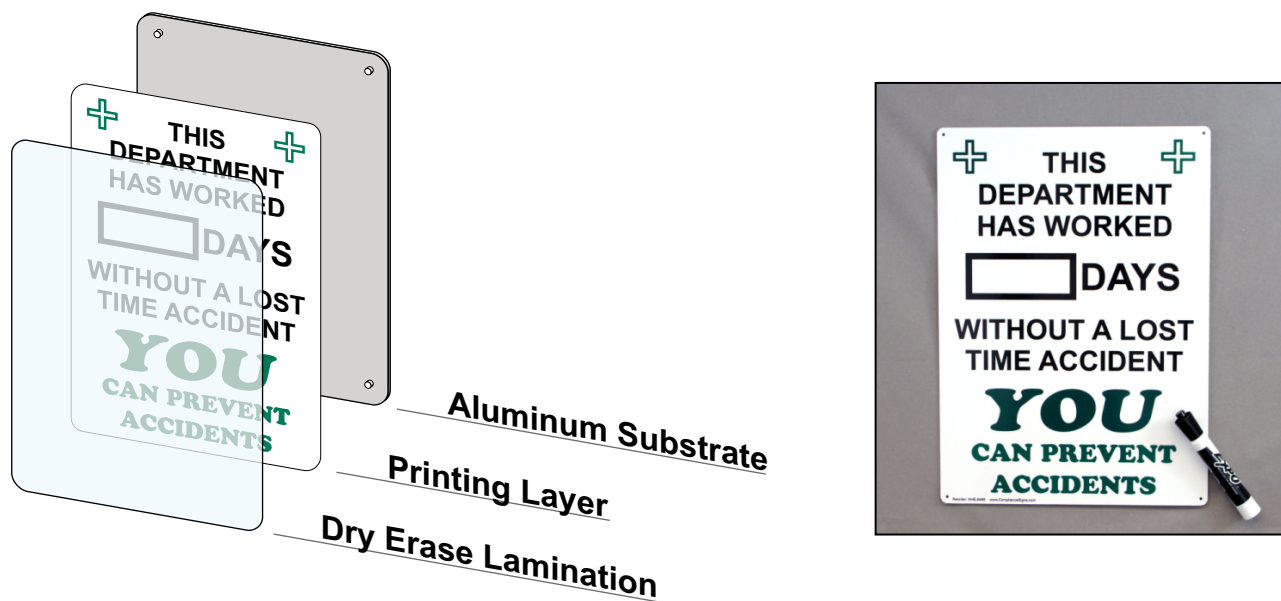

Specifications:

- SUBSTRATE:** 0.040" (1mm) aluminum, white enamel coated both sides
- PRINTING LAYER:** 4.0 mil Vinyl with permanent acrylic adhesive
UV Stable Eco-solvent ink
- LAMINATE:** 2.8 mil, Dry Erase Film (Optically Clear)
- Scratch Resistant
 - Resistant to Dry Erase Ink Formulations
 - Limited UV Resistance for Laminate. Test before outside use.
- MOUNTING:** 0.20" diameter holes in each of 4 corners
Holes offset 0.25" from adjacent edges
Mounting hardware not included
- CORNERS:** 0.25" Radius Corners
- OPTIONS:** Available for additional charge:
- Adhesive backing with or without holes
 - Reflective or Glow-in-the-Dark

Engraved Signs

Product Data Bulletin

Description:

A solid color acrylic core is manufactured with a color surface layer. Laser engraving selectively removes portions of the color layer to expose the solid color core. Signs can be supplied as shown with permanent adhesive for mounting, or with a mounting bracket.

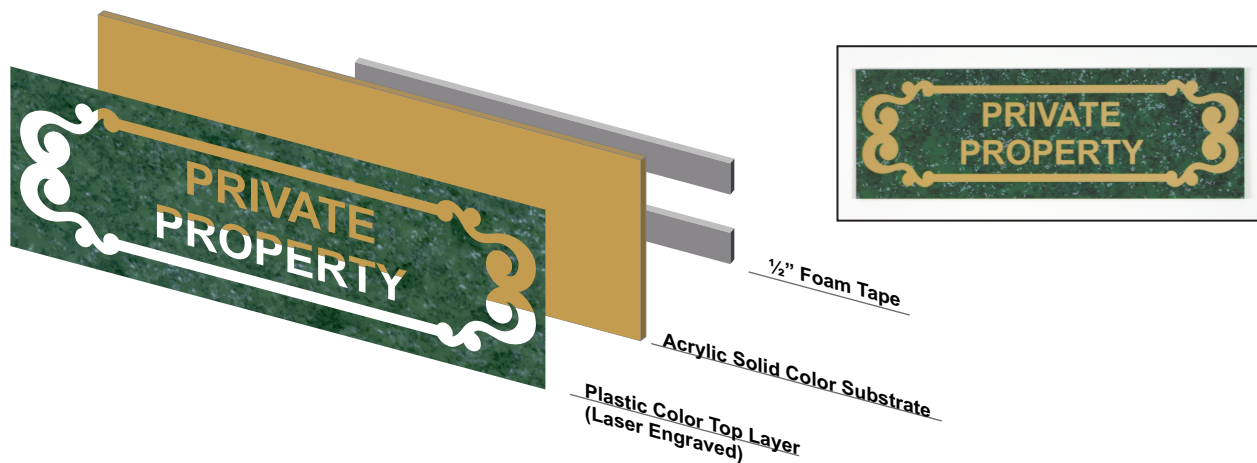

Specifications:

SIGN CONSTRUCTION:

Overall thickness of all layers is 0.063"
Laser engraving removes the surface color to reveal the solid color core.

MOUNTING:

Two strips of 1/2" double-sided foam tape.

OPTIONS:

Brackets for screw mounting and easy plate change are available for extra charge. Please inquire for specialty colors and finishes.

Fence EasyMount

Product Data Bulletin

Description:

For convenient one-person sign installation, Fence EasyMount mounting brackets are your best choice. Made for securing signs to chain link fences, prevents movement from wind, child tampering, or vandalism. Pre-assembled with an integrated nut, mounting screw and fence anchoring screw.

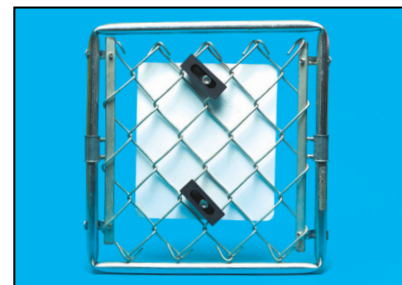
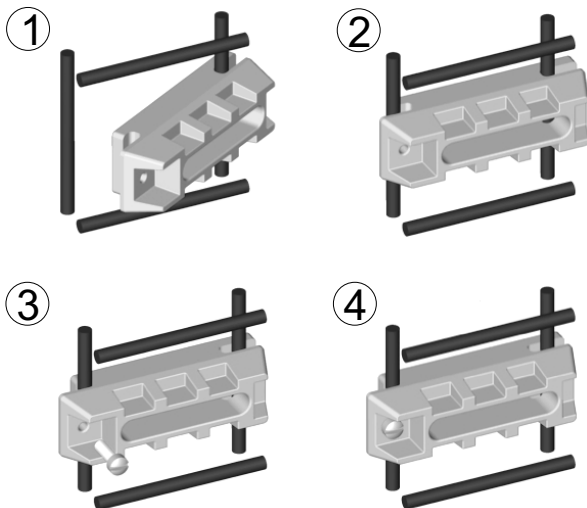

Glow-in-the-Dark

Product Data Bulletin

Description:

Strontium Oxide Aluminate pigment glow in the dark sheeting is printed with UV resistant eco-solvent ink. Print is laminate with UV, chemical, abrasion, and moisture resistant coating. Ideal for indoor and outdoor business and industrial use. Available as a permanent self adhesive label or pre-applied to a wide variety of rigid and semi-rigid substrates. Service temperature not to exceed +120 F.

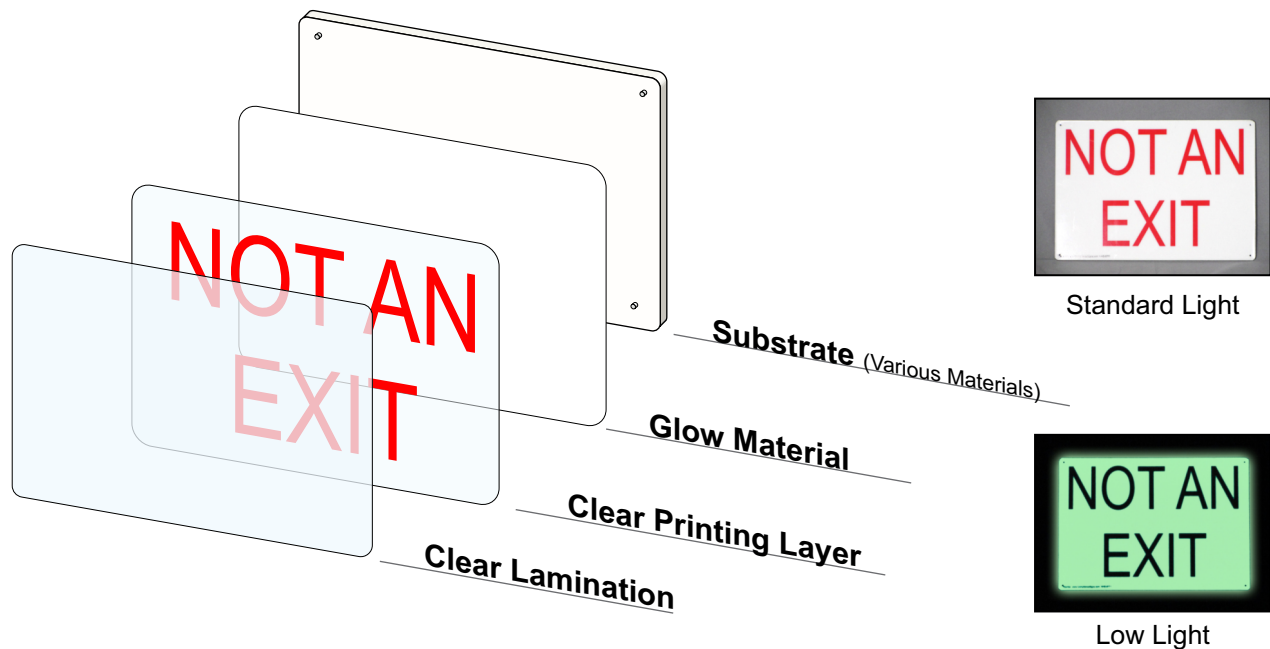

Specifications:

- SUBSTRATE:** Available as permanent, self adhesive label or pre-applied to a wide selection of rigid or semi-rigid substrates. (Aluminum, Plastic, Magnetic)
- GLOW LAYER:** Strontium Oxide Aluminate pigmented - flexible PVC with acrylic, permanent adhesive. Non-radioactive
- PRINTING LAYER:** 3.4 mil PVC clear film printed with UV Stable Eco-solvent ink
- LAMINATE:** 2.5 mil, PVC Film (Optically Clear)
- Scratch Resistant
 - Chemical Resistant
 - UV Resistant
- OPTIONS:** Available for additional charge:
- Anti-graffiti and Anti-Skid / floor laminates
 - Higher luminance, higher duration glow materials available as required

Magnetic

Product Data Bulletin

Description:

Flexible magnetic vinyl substrate signs printed with UV resistant eco-solvent ink, reinforced with UV, chemical, abrasion, and moisture resistant laminate layer. Recommended for indoor and outdoor business and industrial environments. Service temperatures range -15 F to +160 F.

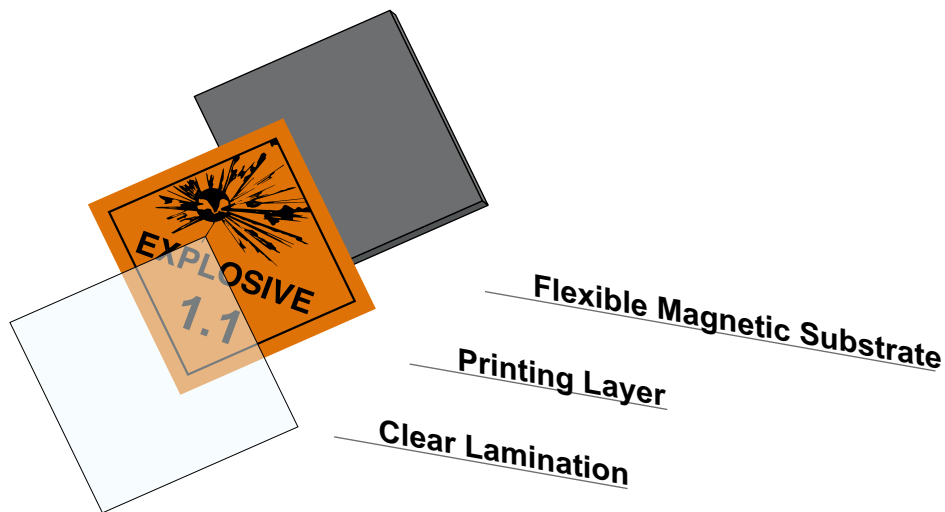

FRONT

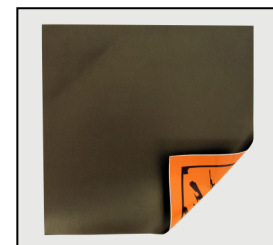

REAR

Specifications:

SUBSTRATE:	0.030" (0.76 mm) magnetic vinyl, flexible
PRINTING LAYER:	4.0 mil Vinyl with permanent acrylic adhesive UV Stable Eco-solvent ink
LAMINATE:	2.5 mil, PVC Film (Optically Clear) <ul style="list-style-type: none">• Scratch Resistant• Chemical Resistant• UV Resistant
MOUNTING:	Magnetic multipole, Minimum pounds pull at zero air gap = 12 ppi (lbs / inch)
OPTIONS:	Reflective or Glow-in-the-Dark are available for additional charge.



Mounting Accessories

Product Data Bulletin

Introduction:

ComplianceSigns.com offers a variety of sign posts, sign mounting hardware, sign bases, mounting tape and more to mount your safety signs indoors or out. We offer three styles of sign posts, aluminum and poly post bases, three types of fence-mounting kits and tamper-resistant bolt kits.



4-foot Economy Sign Post

- U-channel steel sign post / stake with green enamel coating
- 4-foot post is rated at 1.12 pounds per foot
- Includes Sign Mounting Hardware Kit (Two each: 2-inch bolt, flat washer, split-ring lock washer and nut)
- Ideal for use with our convenient 15-inch aluminum post base or 18-inch poly base



7-foot Economy Sign Post

- U-channel steel sign post / stake with green enamel coating
- 7-foot post is rated at 1.12 pounds per foot
- Includes Sign Mounting Hardware Kit (Two each: 2-inch bolt, flat washer, split-ring lock washer and nut)
- Install by pounding into the ground or use the convenient 15-inch Aluminum Post Base
- Not recommended for use with our Poly base



8-foot Standard Sign Post

- U-channel steel sign post / stake with green enamel coating
- 8-foot post is rated at 2 pounds per foot
- Includes Sign Mounting Hardware Kit (Two each: 2.5-inch bolt, flat washer, split-ring lock washer and nut)
- Install by pounding into the ground or use the convenient 15-inch Aluminum Post Base
- Not recommended for use with our Poly base

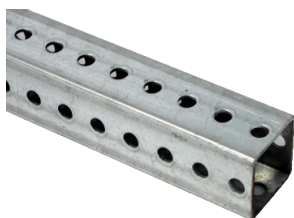

8-foot Premium Sign Post

- Great for demanding applications
- Square galvanized steel with perforations on all 4 sides
- 8-foot sign post is rated at 2 pounds per foot
- Includes Sign Mounting Hardware Kit (Two each: 2.5-inch bolt, flat washer, split-ring lock washer and nut)
- Tamper resistant mounting hardware is available
- Install by pounding into the ground, or use our optional 3-foot Post Sleeve or 15-inch Aluminum Post Base
- Not recommended for use with our Poly base



Mounting Accessories

Product Data Bulletin



Steel Post Sleeve

- Recommended when installing signs using our Premium Sign Posts
- Square galvanized steel with perforations on all 4 sides for easy sign mounting in any direction
- 3-foot long sleeve is easier to set in cement or pound into the ground than the full 8-foot post.
- Hardware kit includes two sets of corner bolts, flat washers and hex nuts



18-inch diameter Black Polymer Base

- Fill with sand or water for stability
- Recommended for use with our 4-foot U-channel Economy Post
- Easy to move into position wherever you need a temporary sign, or for locations where a permanently mounted sign could be a hazard
- Poly base is suitable for use indoors or out
- Not recommended for use with posts longer than 4 feet



15-inch diameter Aluminum Post Base

- Great for mounting your sign on any hard, level surface - including concrete or asphalt
- Removable mounting insert allows use with our Economy Posts, U-channel Standard Posts or square Premium Posts.
- Includes hardware to install insert and sign post (no sign-mounting bolts)
- 6 pounds in weight (Must be bolted down when using 7-foot or 8-foot posts or in windy locations)
- 3 predrilled holes make it easy to anchor the base (bolts not included)



Standard Bond Mounting Tape

- Double-sided foam tape is tacky on one side and has an easily removed backing on the other side
- 1 inch wide x 36 yards long
- Fast and easy to use
- Surfaces must be dry and oil / dust free
- Not recommended for use on powder-coated steel, prominently grained or unfinished wood



Mounting Accessories

Product Data Bulletin



Tamper Resistant Hardware

- Specially made nuts break away during installation, leaving a tamper-resistant cone to hold the bolt
- Use with U-channel Standard and square Premium posts
- Kit contains 2- 2.5 inch carriage bolts and 2-breakaway nuts
- Bolts and nuts are size 5/16-18
- During installation, once the breakaway nuts are tight, continue tightening with firm pressure to break off the hex head, leaving the tamper-resistant cone



Fence Strap

- Recommended to mount signs that have two holes, such as parking signs, to open chain link fences.
- Each strap is 4 inches wide and has two holes that align with the spacing of ComplianceSigns.com parking style signs
- Order a strap that matches the height of your sign (9, 12, 18 or 24 inch)
- Mounting hardware includes: 2- 1 inch bolts, 2- flat washers, 2- split-ring lock washers and 2- nut fasteners

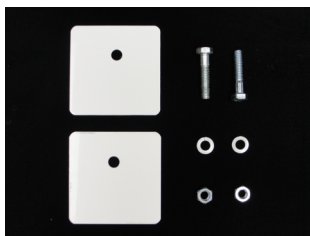

Fence Sign Mount

- For easy, adjustable mounting of any sign on open chain link fence
- Aluminum square (3x3 in) with rounded corners
- Offset hole lets you adjust sign alignment
- Mounting hardware includes: 2- 1 inch bolt, 2- split-ring lock washers and 2- matching nuts

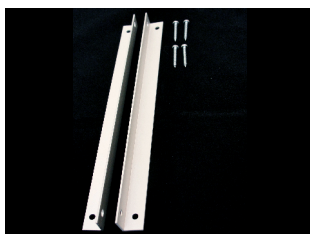

T-Bracket

- 2- .75 x .75 inch aluminum brackets 9 inches long
- Sign comes assembled to T-bracket held in place with 2- 1/8" rivets
- Mounting hardware includes 2- #6x1" zinc plated screws



Mounting Accessories

Product Data Bulletin



Utility Markers

- Recommended to mount utility labels
- Fiberglass-reinforced composite for strength and flexibility
- 4 inches wide x 66 inches high
- Offered in Blue, Brown, Green, Orange, Red, White, and Yellow
- Easy installation with standard marker driving tool



Stake

- Made of textured polyethylene
- 2 inches wide x 24 inches high
- .375 inch thick
- Mounting hardware includes: 2-1/4" 20 x 3/4" stainless steel screws



DOT Bracket - Snap

- Stainless steel clip helps hold placards in place
- Brite mill metal finish on .032 aluminum
- Measures at 18.25x18.25 inch
- Recommended for 10.75x10.75 metal and non-adhesive tagboard and rigid vinyl placards
- Ideal for use on smooth-sided trailers



DOT Bracket

- Brite mill metal finish on .032 aluminum
- Measures at 17.25x17.25 inch
- Recommended for 10.75x10.75 metal and non-adhesive tagboard and rigid vinyl placards
- Ideal for use on smooth-sided trailers

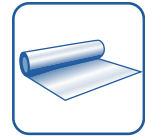

Parking Control Signs

Product Data Bulletin

Description:

Extra rigid aluminum substrate signs printed on engineer grade reflective sheeting with UV resistant eco-solvent ink. Laminated with UV, chemical, abrasion, and moisture resistant clear sheeting, Ideal for outdoor business and industrial environments.

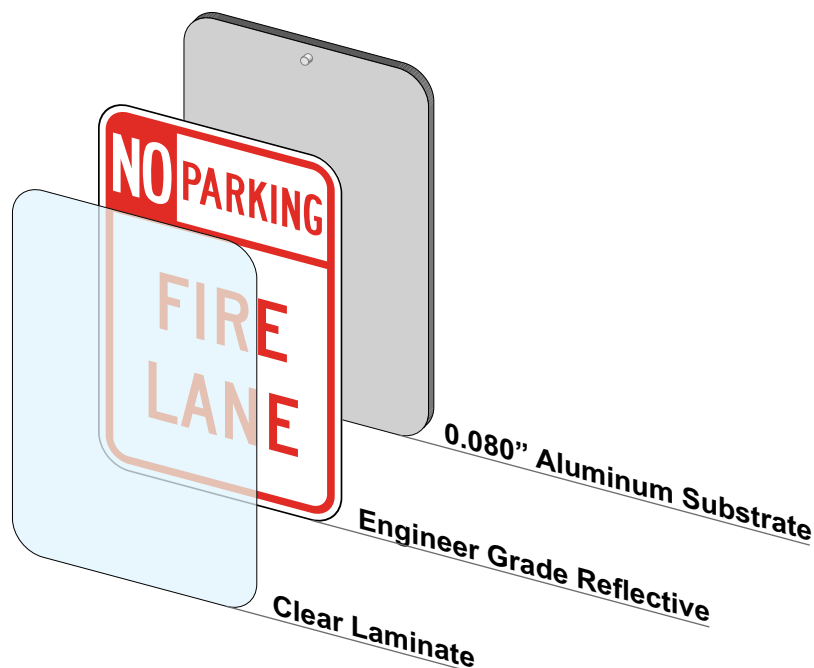

Normal Light Conditions

Low Light Conditions

Specifications:

SUBSTRATE:	0.080" (2mm) aluminum
PRINTING LAYER:	3M 3290 Engineer Grade Reflective Vinyl UV Stable Eco-solvent ink
LAMINATE:	2.5 mil, PVC Film (Optically Clear) <ul style="list-style-type: none">• Scratch Resistant• Chemical Resistant• UV Resistant
MOUNTING:	Two 0.38" diameter holes centered Holes offset 1" from adjacent edges Mounting hardware not included
CORNERS:	1.5" Radius Corners
OPTIONS:	Anti-graffiti laminate option available for additional charge

Pipe Wrap

Product Data Bulletin

Description:

Semi-rigid PVC is printed with UV resistant, ecosolvent ink. A permanent adhesive, foam tape strip allows the plastic to be securely fastened after wrapping around a pipe. The tape sticks to the plastic wrap rather than the pipe, allowing the wraps to adjust to different pipe diameters, and to be wrapped around pipes with dirty or wet surfaces. Recommended for indoor and outdoor business and industrial environments. Service temperatures up to +150 F.

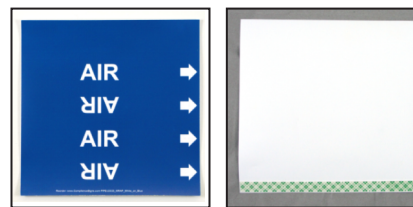
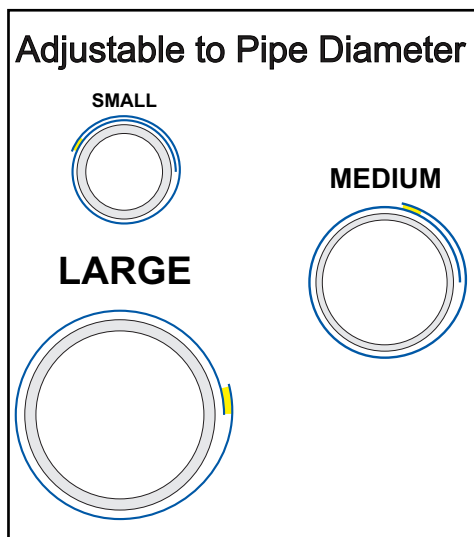
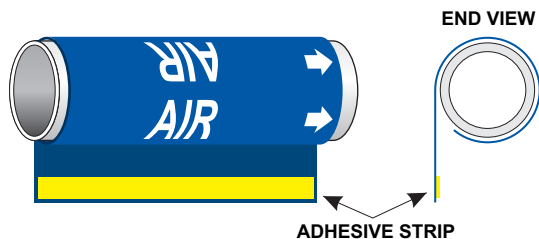

FRONT

REAR

Specifications:

- SUBSTRATE: 9 mil Semi-rigid PVC
- PRINTING LAYER: UV Stable Eco-solvent ink - direct to substrate printing
- MOUNTING: Double-sided permanent acrylic adhesive foam tape

Poly Film

Product Data Bulletin

Description:

The polypropylene film is a tear resistant material with water resistant satin coating making it ideal for high quality outdoor and high humidity applications. This film is dimensionally stable, which means it will not shrink or buckle. It also looks great with higher quality displays and images, even at close-up viewing.

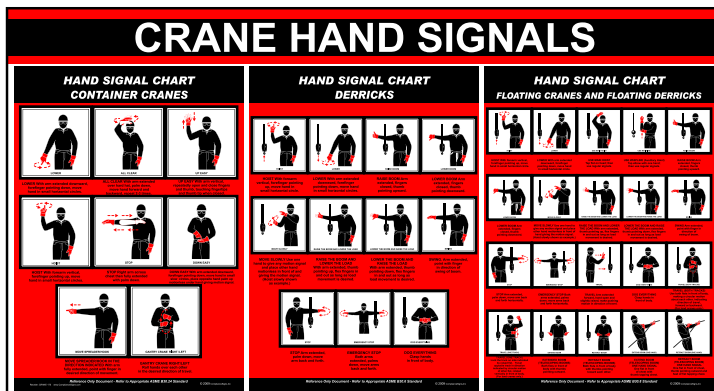

Printing Layer

Specifications:

- PRINTING LAYER:** 7.0mil Satin finish polypropylene film
UV Stable Eco-solvent ink
- LAMINATE:** No lamination necessary because of water-fast coating
- MOUNTING:** Double-sided foam tape (not included)

PVC Plastic Signs

Product Data Bulletin

Description:

Plastic substrate signs printed with UV resistant eco-solvent ink, reinforced with UV, chemical, abrasion, and moisture resistant laminate layer. Recommended for indoor and outdoor business and industrial environments. Service temperature range -40 F to +176 F.

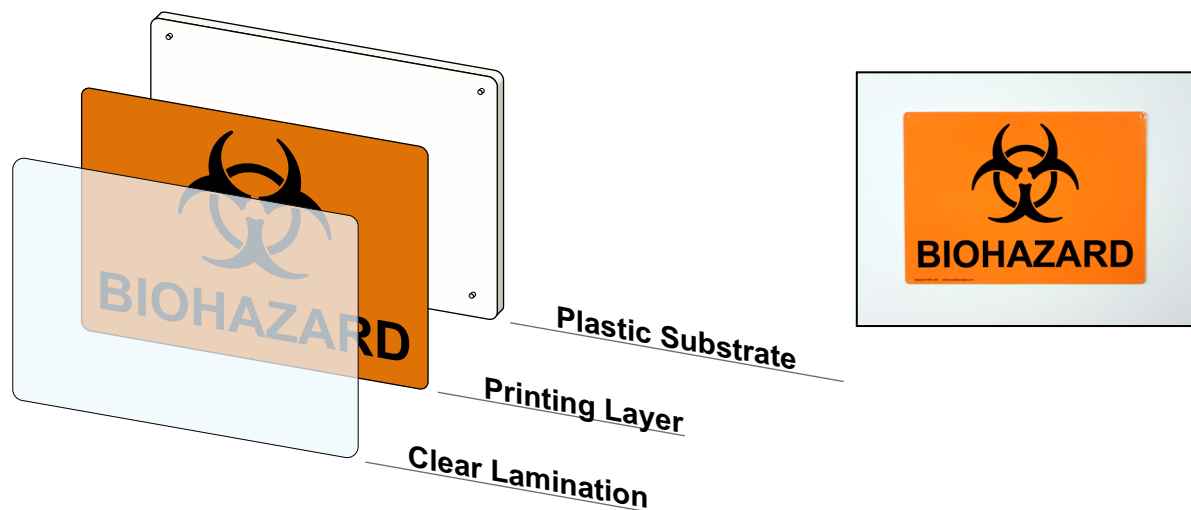

Specifications:

SUBSTRATE:	0.04" (1mm) Low Density / Semi-Rigid PVC Plastic
PRINTING LAYER:	4.0 mil Vinyl with permanent acrylic adhesive UV Stable Eco-solvent ink
LAMINATE:	2.5 mil, PVC Film (Optically Clear) <ul style="list-style-type: none">• Scratch Resistant• Chemical Resistant• UV Resistant
MOUNTING:	0.20" diameter holes in each of 4 corners Holes offset 0.25" from adjacent edges Mounting hardware not included
CORNERS:	0.25" Radius Corners
OPTIONS:	Available for addition charge: <ul style="list-style-type: none">• Adhesive backing with or without holes• Reflective or Glow-in-the-Dark• Anti-graffiti and Anti-skid / Floor laminate options

PVC Tag

Product Data Bulletin

Description:

Flexible plastic is printed with UV resistant, ecosolvent ink. Tag is attached to equipment with cable tie. Recommended for indoor and outdoor business and industrial environments. Service temperatures up to +150 F.



Front



Back

Specifications:

- SUBSTRATE: 0.015" Flexible PVC Plastic
- PRINTING LAYER: UV Stable Eco-solvent ink - direct to substrate printing
- GROMMET: 3/8" diameter - Brass
- MOUNTING: 7" or 11" - 50 lb Cable Tie

Reflective

Product Data Bulletin

Description:

Engineer grade retro-reflective sheeting is printed with UV resistant eco-solvent ink. Print is laminated with UV, chemical, abrasion, and moisture resistant coating. Ideal for outdoor business and industrial use. Available as a permanent self adhesive label or pre-applied to a wide variety of rigid and semi-rigid substrates.

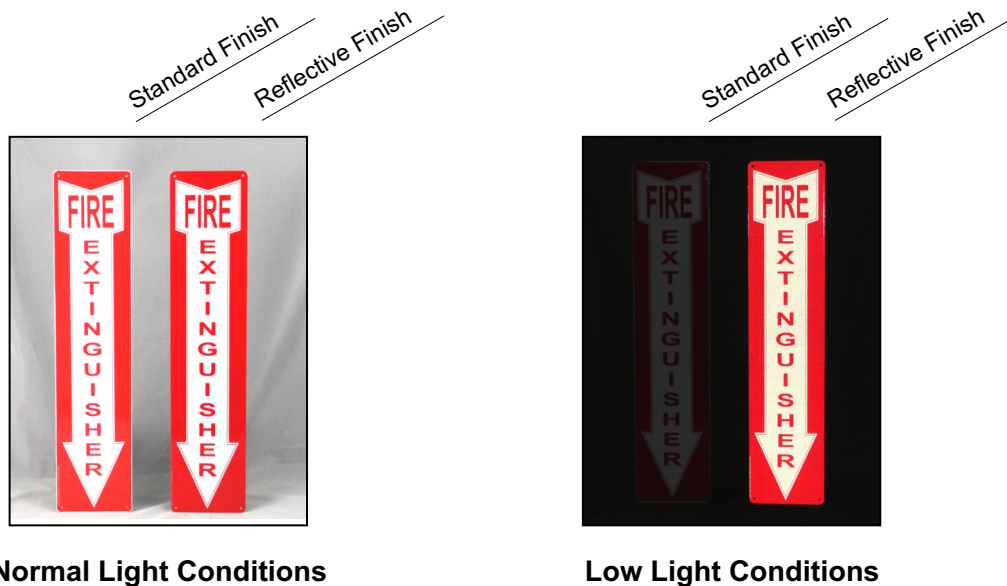

Specifications:

- SUBSTRATE:** Available as permanent, self adhesive label or pre-applied to a wide selection of rigid or semi-rigid substrates, (Aluminum, Plastic, Magnetic)
- PRINTING LAYER:** 3M 3290 Engineer Grade Reflective Vinyl
UV Stable Eco-solvent ink
- LAMINATE:** 2.5 mil, PVC Film (Optically Clear)
- Scratch Resistant
 - Chemical Resistant
 - UV Resistant
- OPTIONS:** Anti-graffiti laminate available for additional charge.

Self Adhesive Labels & Stickers

Product Data Bulletin

Description:

Self adhesive vinyl labels printed with UV resistant eco-solvent ink, reinforced with UV, chemical, abrasion, and moisture resistant laminate layer. Labels are very flexible for applications where rigid substrates will not function. Recommended for indoor and outdoor business and industrial environments. Service Temperature range -40 F to +176 F.

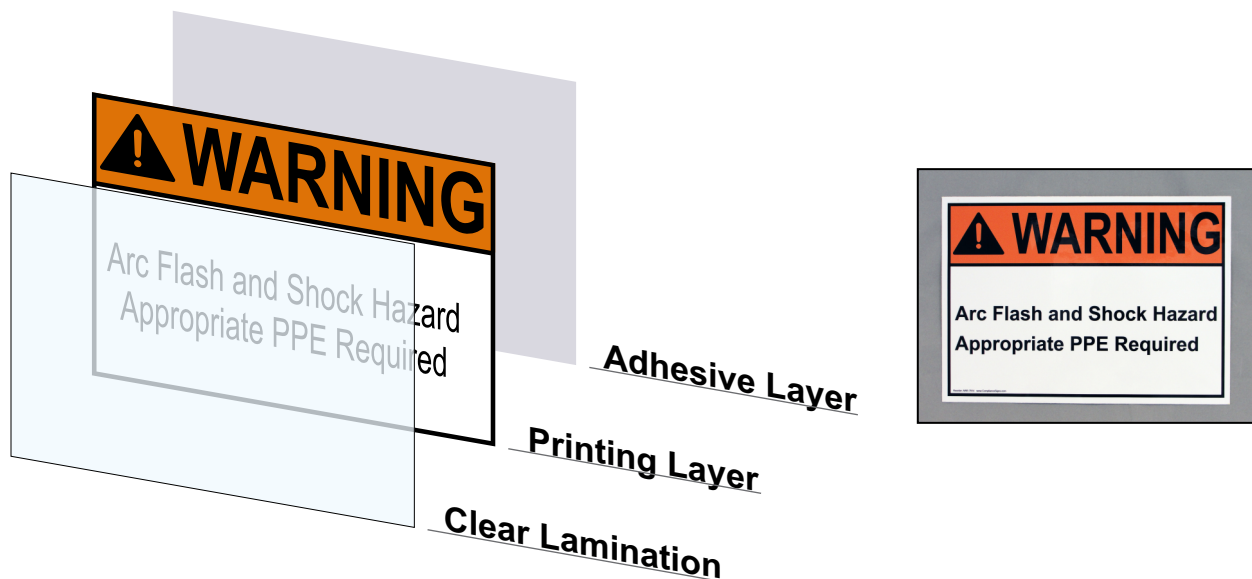

Specifications:

PRINTING LAYER:	4.0 mil gloss Vinyl film printed with UV Stable Eco-solvent ink
LAMINATE:	2.5 mil, PVC Film (Optically Clear) <ul style="list-style-type: none"> • Scratch Resistant • Chemical Resistant • UV Resistant
MOUNTING:	Clear 1.0 mil pressure sensitive, permanent acrylic adhesive with easily removed backing liner
OPTIONS:	Special package and precut sheet quantities Available for additional charge: <ul style="list-style-type: none"> • Reflective or Glow-in-the-Dark Substrate • Anti-graffiti and Anti-skid/Floor Laminates

Sign Frame

Product Data Bulletin

Description:

Wood grained or black painted frames allow recessed mounting of adhesive backed signs. Appropriate for indoor business and retail environments, this framing system adds on elegant flair to posted signs.

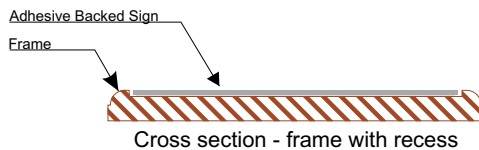

Specifications:

- FRAME MATERIAL:** Warp resistant particle wood product with wood grain or painted surface.
- MOUNTING:** Frames can be mounted with standard picture mounting hardware or foam backed permanent adhesive tape (not included).
- OPTIONS:** Other sizes and finishes available upon request

Sign Plaque

Product Data Bulletin

Description:

Wood grained or black painted plaques allow surface mounting of adhesive backed signs. Appropriate for indoor business and retail environments, this sign display system adds an elegant flair to posted signs.



Specifications:

- PLAQUE MATERIAL:** Warp resistant particle wood product with wood grain or painted surface.
- MOUNTING:** Plaques can be mounted with standard picture mounting hardware or foam backed permanent adhesive tape (not included).
- OPTIONS:** Other sizes and finishes available upon request

Sliding Engraved Signs

Product Data Bulletin

Description:

A solid color acrylic core is manufactured with a color surface layer. Laser engraving selectively removes portions of the color layer to expose the solid color core (See “Engraved Signs” Product Bulletins for details). Signs are mounted in a bracket which allows sliding to indicate room status.

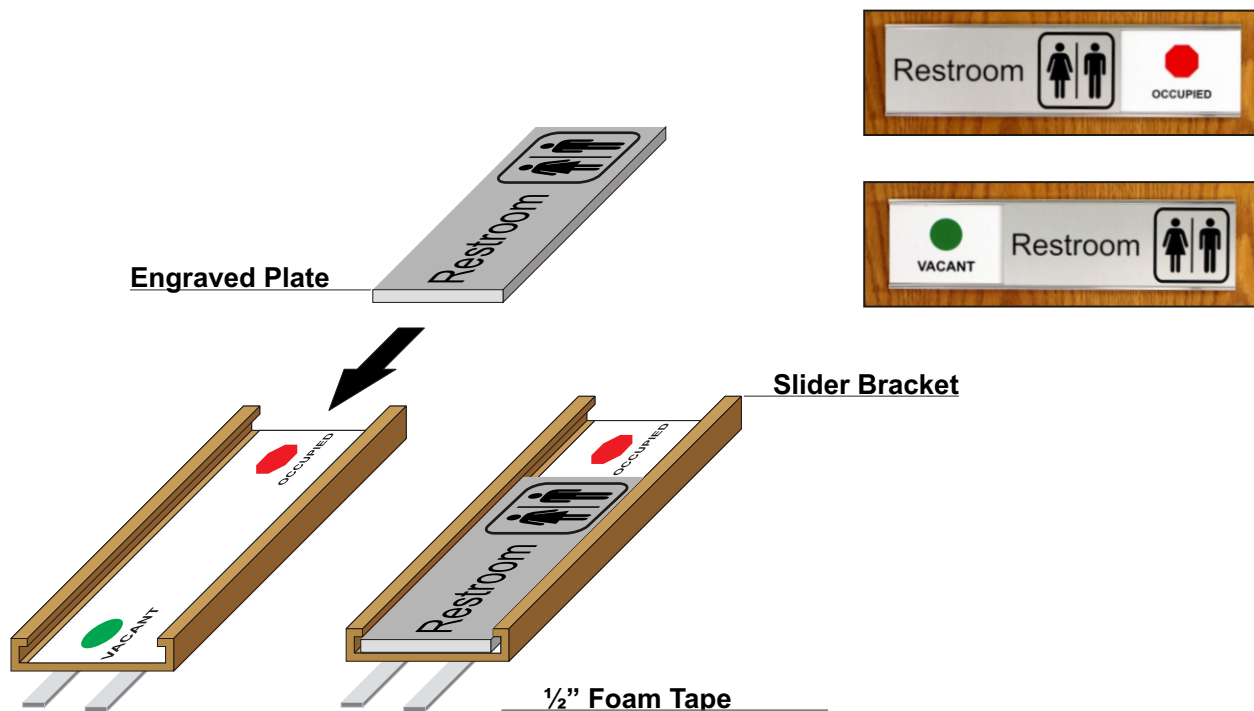

Specifications:

SIGN CONSTRUCTION:

1/16" Solid Color Core with Surface Color co-extrusion layer. Laser engraving removes the surface color to reveal the solid color core.

Sign bracket has printed layer for "VACANT" / "OCCUPIED"

MOUNTING:

Sign slides in bracket.

Bracket mounting via screw holes (not shown) and two strips of 1/2" double-sided foam tape

OPTIONS:

Custom printing to replace "VACANT" / "OCCUPIED" is available. Please enquire for specialty colors and finishes

Stencil

Product Data Bulletin

Description:

Flexible stencil substrate material is laser or pen cut to remove letters and other paint-through areas. Substrate is durable and paint resistant, and can be used multiple times with appropriate care taken during installation. Recommended for indoor and outdoor business and industrial environments. Service temperature of the stencil material usually exceeds that of the paints being used.

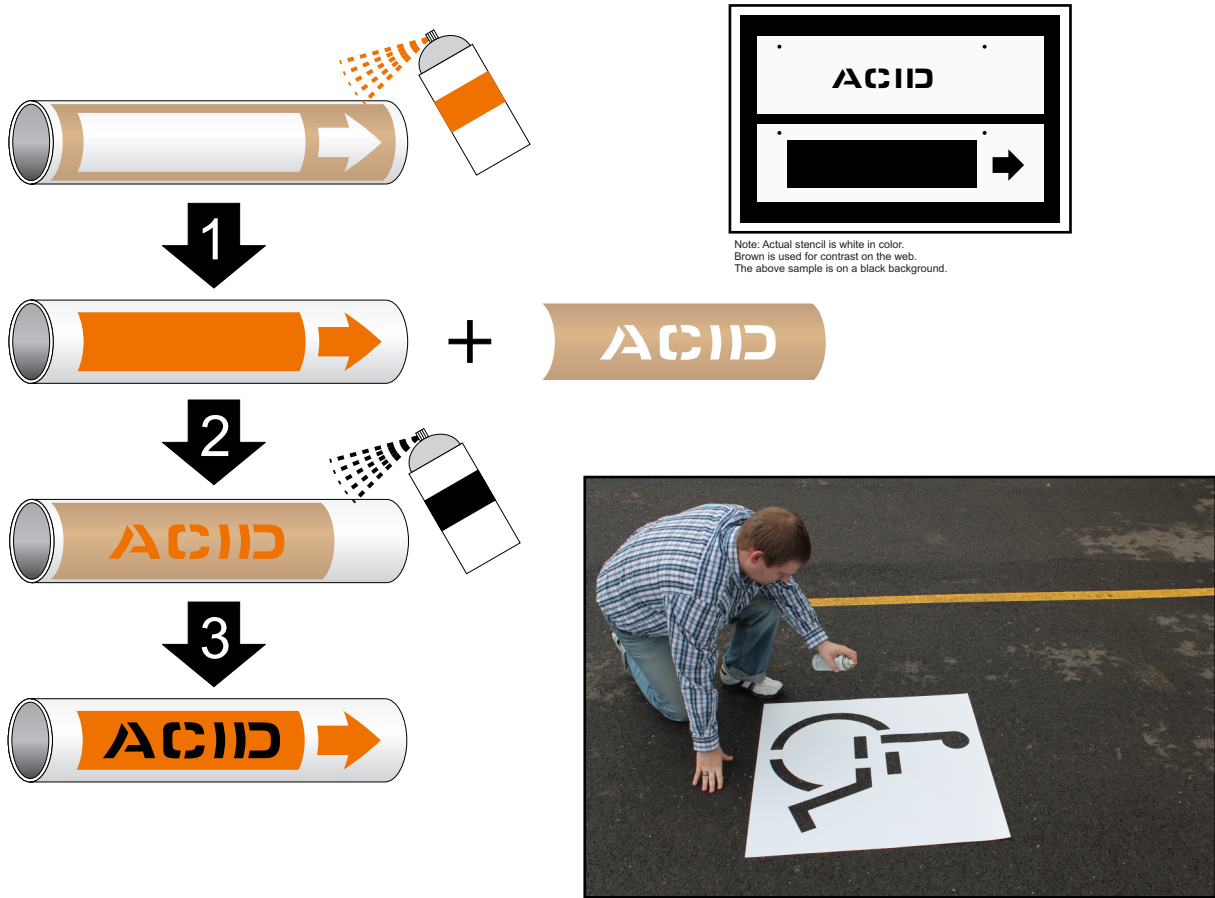

Specifications:

SUBSTRATE: 0.010" Flexible Plastic

OPTIONS: Custom wording, size, fonts, and multilayer stencils with alignment features can be produced to your exact specifications.

Sublimation Process and Materials

Product Data Bulletin

Description:

Sublimation is a “dry” printing method by which heat and pressure force ink below the top surface of a sublimation primed substrate. The sublimation process allows for vibrant colors, and preserves special finishes and grain patterns of the substrates printed. Suitable for indoor business, office, and retail environments.

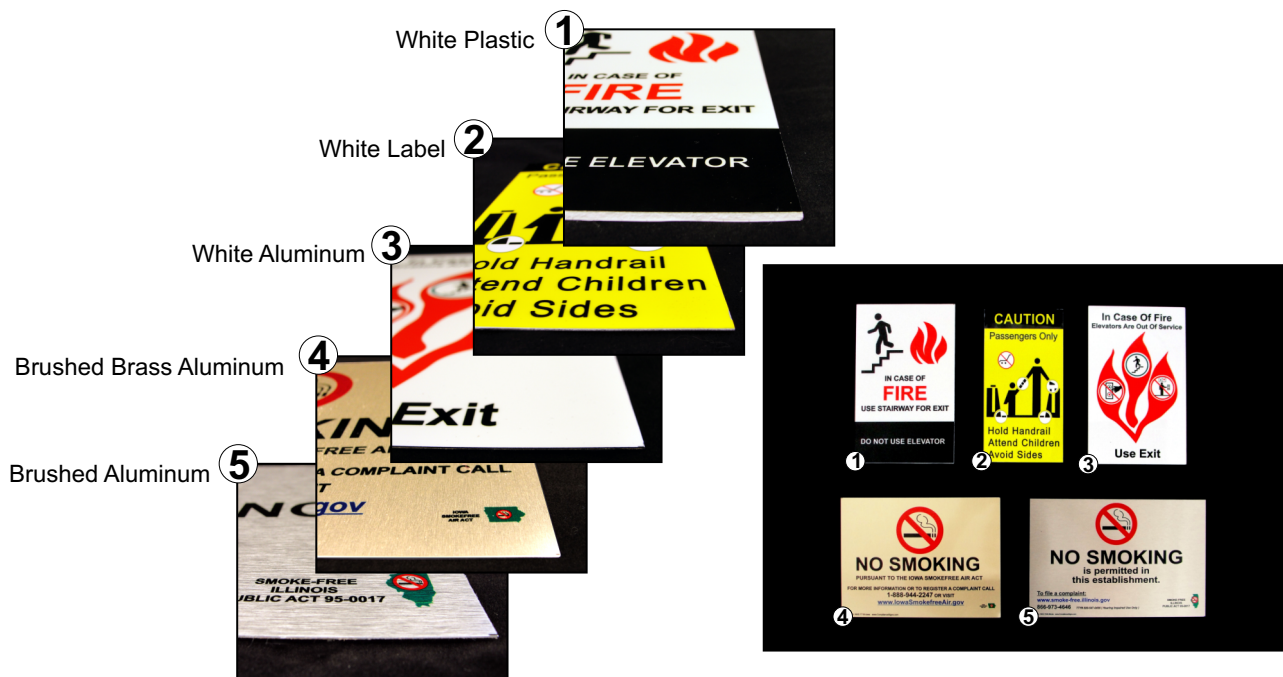

Specifications:

AVAILABLE SUBSTRATE:

- Plastic- PVC, 0.100” Thickness
 - 1- White Finish
- Label- Self Adhesive 4 mil Thickness
 - 2- White Finish
- Aluminum- 0.020” Thickness
 - 3- White Finish
 - 4- Brushed Brass Finish
 - 5- Brushed Aluminum Finish

PRINTING LAYER:

Sublimation ready polyester or PVC based transparent coating.

MOUNTING:

Substrates are provided with adhesive backing. Can be mounted to optional recessed frames or surface mount plaques.

OPTIONS:

Available with adhesive or mounted to frames or plaques.

Tape

Product Data Bulletin



Anti-Slip

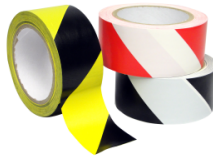

Hazard



Marking



Pipe Marking



Reflective



Vehicle

	Application	Adhesive	Material	Thickness	Shelf Life	Specification
Anti-Slip	Minimum application temperature 50°F. Surface must be clean and free from dust, dirt, oil, wax, silicone	Permanent Acrylic Pressure Sensitive	Vinyl (6 mil) 46-Grit	0.034 in	1 year stored at 70°F	ASTM-D638 PSTC-33 PSTC-7 PSTC-6 PSTC-1
Hazard	Conformable to most any surface, and will adhere to most clean dry surfaces.	Crosslinked Rubber Adhesive Pressure Sensitive	Vinyl (6 mil)	6.8 mil	1 year stored at 70°F	PPP-T-66E
Marking	Great for floor aisle marking and color-coding pipe banding applications. The coloring is throughout the vinyl so it can not scratch or scuff during wear.	Crosslinked Rubber Adhesive	Vinyl (6 mil)	6.8 mil	1 year stored at 70°F	PPP-T-66E
Pipe Marking	Minimum application temperature 10°F. Operational temperature -50°F to 120°F. Surface must be clean and free from dust, dirt, oil, wax, silicone.	Permanent Rubber	3.0 mil polyethylene 1.0 mil biaxially-oriented polypropylene lamination	4.0 mil	1 year stored at 72°F	
Reflective	Minimum application temperature 40°F. Surface must be clean and free from dust, dirt, oil, wax, silicone.	Permanent Acrylic Pressure Sensitive	Reflective	4.5-5.5 mil	1 year stored at 73°F	ASTM-D4956 DOT-C2
Vehicle Reflective	Minimum application temperature 60°F. Recommended for flat application to clean painted metal surfaces only. Not recommended for stainless steel.	Permanent Acrylic Pressure Sensitive	Vinyl Based Prismatic Reflective Film	13.0 mil	1 year stored at 73°F	NHTSA (49 CFR 571) DOT-C2

Restroom Signs (Page 1 of 5)

Product Group - Offering Summary

Introduction:

ComplianceSigns.com has a wide selection of restroom signs to meet almost any need. To help you select the sign which meets your exact application, we have assembled this restroom sign summary which describes the signs and the options available for each. For more in depth information, please review our product data bulletins.

ADA Braille:

BRAILLE:
MOUNTING:
LANGUAGES AVAILABLE:
SIGN MATERIAL:
WEB SHORTCUT:

YES
SURFACE / ADHESIVE
English, Spanish, Bilingual
ADA Acrylic - 1/16" Substrate, 1/32" Tactile, Grade 2 Braille
<http://www.compliancesigns.com/Restroom-ADABraille.shtml>



Example

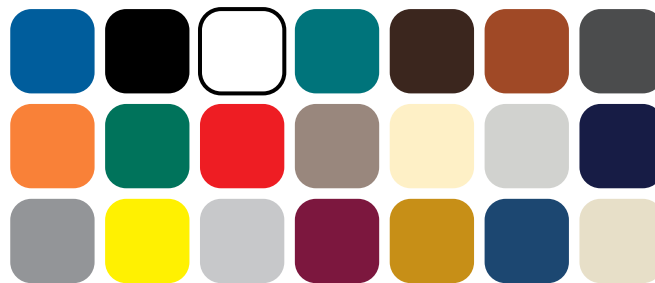

Available Background Colors

California Title 24 - ADA Door Sign:

BRAILLE:
MOUNTING:
LANGUAGES AVAILABLE:
SIGN MATERIAL:
WEB SHORTCUT:

NO
SURFACE / ADHESIVE
English, Spanish, Bilingual
ADA Acrylic - 1/4" Acrylic, 1/32" Tactile
http://www.compliancesigns.com/restroom_Calif24_L2.shtml



Example

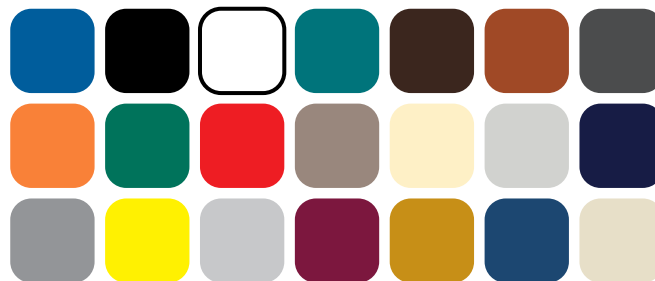

Available Background Colors

Restroom Signs (Page 2 of 5)

Product Group - Offering Summary

Surface Mount:

BRAILLE:
MOUNTING:

LANGUAGES AVAILABLE:
SIGN MATERIAL OPTIONS:
WEB SHORTCUT:

NO
SURFACE
ADHESIVE (Labels), Holes for Fasteners (Aluminum, Plastic)
English, Spanish, Bilingual
Aluminum, Plastic, Self Adhesive Labels, Magnetic
<http://www.compliancesigns.com/restroom.shtml>



Example

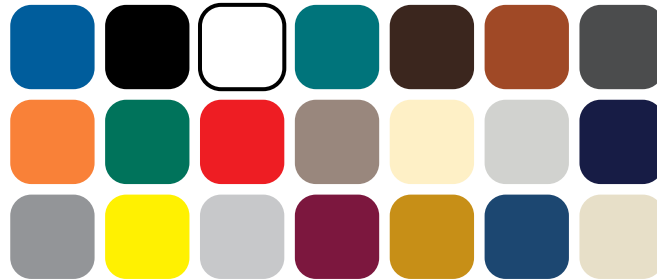

Available Background Colors

2D Projection Mount - Protrudes from Wall:

BRAILLE:
MOUNTING:
LANGUAGES AVAILABLE:
SIGN MATERIAL:
WEB SHORTCUT:

No
Adhesive + Holes in Flange for Fastener Mounting
English, Spanish, Bilingual
Aluminum
<http://www.compliancesigns.com/restroom.shtml>



Example

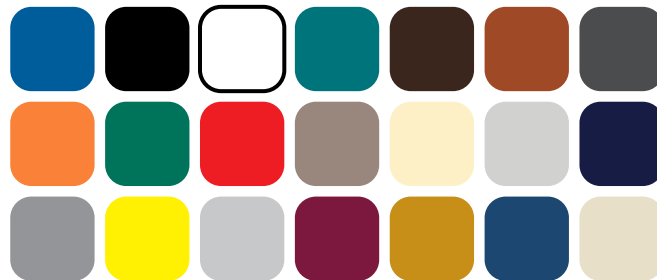

Available Background Colors

Restroom Signs (Page 3 of 5)

Product Group - Offering Summary

3D Triangle Mount - Protrudes from Wall:

BRAILLE:	No
MOUNTING:	Adhesive + Holes in Flange for Fastener Mounting
LANGUAGES AVAILABLE:	English, Spanish, Bilingual
SIGN MATERIAL:	Aluminum
WEB SHORTCUT:	http://www.compliancesigns.com/restroom.shtml

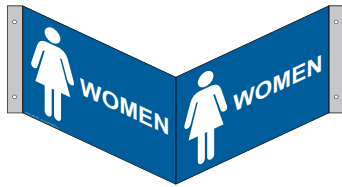

Example

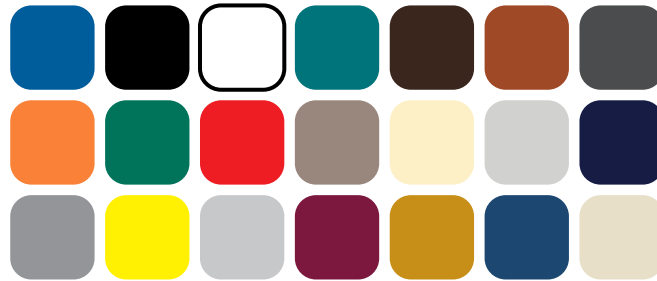

Available Background Colors

2D Projection Mount - Hangs from Ceiling:

BRAILLE:	No
MOUNTING:	Hangs between track and tile on drop ceiling
LANGUAGES AVAILABLE:	English, Spanish, Bilingual
SIGN MATERIAL:	Aluminum
WEB SHORTCUT:	http://www.compliancesigns.com/restroom.shtml



Example

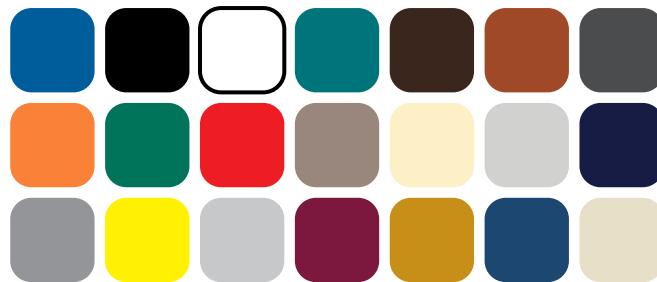

Available Background Colors

Restroom Signs (Page 4 of 5)

Product Group - Offering Summary

Engraved:

BRAILLE: No
 MOUNTING: Adhesive Only or Optional Bracket (Silver or Brass finish)
 LANGUAGES AVAILABLE: English, Spanish, Bilingual
 SIGN MATERIAL: 2-ply laser engraved plastic
 WEB SHORTCUT: <http://www.compliancesigns.com/Restroom-SmallFormat-EngravedOfficeSigns-SurfaceMt.shtml>



Example

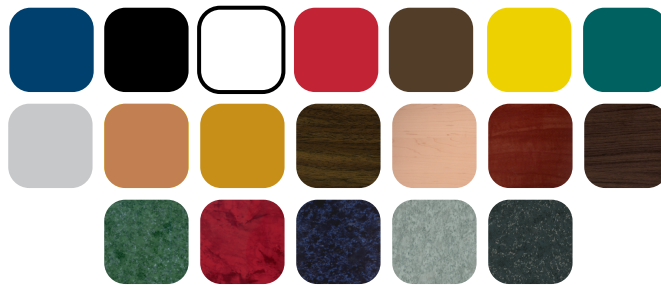

Available Background Colors

Engraved - Slides in Bracket:

BRAILLE: No
 MOUNTING: Bracket Mount - Slides to indicate room status
 LANGUAGES AVAILABLE: English, Spanish, Bilingual
 SIGN MATERIAL: Plastic
 WEB SHORTCUT: <http://www.compliancesigns.com/Restroom-SmallFormat-EngravedOfficeSigns-Slide.shtml>

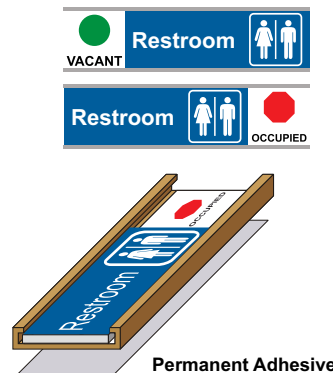

Example

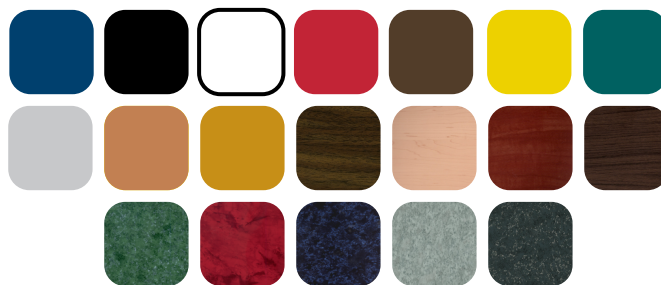

Available Background Colors

Restroom Signs (Page 5 of 5)

Product Group - Offering Summary

ADA Braille - Small Format:

BRAILLE:	YES
MOUNTING:	Adhesive Only or Optional Bracket
LANGUAGES AVAILABLE:	English, Spanish, Bilingual
SIGN MATERIAL:	2-ply laser engraved plastic with Grade 2 Braille
WEB SHORTCUT:	http://www.compliancesigns.com/Engraved_Braille.shtml



Example

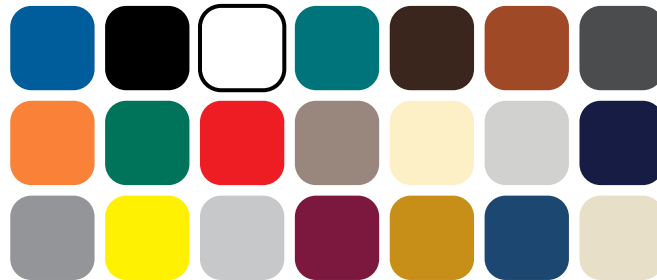

Available Background Colors



Orders

Terms and Conditions

The Signs Point to ComplianceSigns.com

Shopping for workplace signs and decals should not be a difficult ordeal. It should be an easy experience. Experience the ComplianceSigns.com difference. Recognizing demographic shifts in workplace environments, ComplianceSigns.com offers English, Spanish (other languages upon request) and bilingual signs. Materials and finishes offered include aluminum, plastic, magnetic, reflective, glow-in-the-dark, and permanent adhesive labels.

If we do not have the product or size you need in our huge selection, we will produce it to your exact specifications at no additional cost through our online custom sign generator or simply contact us with your specification needs.

Order Changes or Cancellations

You may cancel your order for any reason, and receive a full refund provided your order has not been shipped. If you want to cancel your order with us, please do so quickly, most of our products are shipped within 3 to 5 business days. You must receive a confirmation of your cancellation either over the phone and/or by email for it to be "officially canceled".

If you need to make changes to your order or shipping address please call our Customer Service Department. Once an item has shipped, the terms of our Returns policy will take effect.

Ordering as easy as 1-2-3!



1 Visit your page and select sign



2 Choose quantity and material



3 Checkout

Do not see what you need in our selection? ComplianceSigns.com can still help. Create your own signs with customized wording and sizing and do it all online at www.ComplianceSigns.com or give us a call.



Payment Terms

Terms and Conditions

Flexible:

We accept many forms of payment to make it easy for you to purchase the way *you* want to. We accept company purchase orders, credit cards (Visa, MasterCard, American Express and Discover... including government "P" cards), PayPal and Google Checkout.

Secure:

We protect your payment information behind several layers of security, using "best practices" for web e-commerce transactions:

- All transactions are processed on a remote secure server using a state-of-the-art credit card gateway from FirstData.
- Our site is PCI compliant, and has received Extended Validation Certification from GeoTrust.
- Our website is regularly audited by Guardian Ecommerce and McAfee.
- Our site does not store your credit card information, so when your transaction has been processed, there are no account numbers for potential hackers to steal.





Shipment

Terms and Conditions

Shipment Process:

Orders are processed in order they are received. Normal processing time is two business days. If for some unforeseen reason, an item is no longer available or will be back ordered for an extended period of time, you will be notified immediately. Upon verification and approval of payment, merchandise will be shipped out as soon as possible. Shipping times represent the time it normally takes your package to arrive from the day we actually send it out, not from the day you submit your order. Processing and shipping times exclude Saturdays, Sundays, and holidays.

IF YOUR ORDER IS ESPECIALLY URGENT, WE STRONGLY RECOMMEND CONTACTING US DIRECTLY SO THAT WE MAY EXPEDITE SHIPPING.

ComplianceSigns.com uses FedEx as its primary shipper. Transit time is dependent on the level of FedEx service selected on each order. ComplianceSigns.com is not responsible for delays in shipping due to weather, mechanical failures, typographical and/or transcribing errors, and other factors beyond our control.

Contact our Customer Service Department if an alternate shipping carrier is required. For larger items that ship via Common Carrier, ComplianceSigns.com will make assist in shipping arrangements.





Return Policy

Terms and Conditions

Return Policy:

In order to offer the widest possible selection of signs, ComplianceSigns.com manufactures most of its products after an order is received. At ComplianceSigns.com, we want you to be satisfied with your purchasing experience. If you need to make changes to your order after you have received it the following outlines our return / exchange policy:

Please email sales@ComplianceSigns.com or call **800-578-1245** to authorize any return or exchange. We cannot accept any return or exchange without prior authorization.

We are only able to honor return / exchange requests made within **30 days of the original ship date**. Custom signs cannot be returned or exchanged unless they are damaged or defective.

Replacement:

If your signs / labels arrive damaged, defective, or incomplete, please give us the opportunity to replace them with new signs or labels at our cost. If we are unable to fix the issue, we will refund your money (including shipping and return shipping) promptly upon return of the affected product.

Exchanges:

We will exchange items purchased from us for products of equal value. You are responsible for shipping costs on the new product and return shipping on the existing product. If new products are sent before we receive your return, we will issue credit or the returned product promptly upon receipt.

Returns:

We will issue credit for returned product promptly upon receipt. The returned items must be in undamaged condition and suitable for resale. Shipping costs on the original order will not be refunded, and you are responsible for return shipping. Returns shipped "freight collect" cannot be accepted.

Please email sales@complianceSigns.com or call 800-578-1245 for any questions and return authorization.



Warranty and Guarantee

Terms and Conditions

Warranty:

All products are warranted by ComplianceSigns.com to be free of defects in material or workmanship, at the time of shipment. ComplianceSigns.com liability shall be limited to replacement of the product, if it can be determined that the product was defective at the time of shipment. Defective products, subject to the inspection by ComplianceSigns.com, will be replaced or repaired on a no charge basis. Damage caused by, accidents, or improper use, is the responsibility of the Buyer. ComplianceSigns.com is not responsible for misuse of the products, or if the Buyer is unable to use the product. This warranty is in lieu of any other warranty expressed or implied.

All shipping costs related to returning the product to the Manufacturer for inspection will be prepaid by the buyer. Shipping costs will be reimbursed if parts are determined to be defective. Shipping non-defective parts back to the Buyer will be paid by the Buyer. All expenses, losses in revenue, and labor charges arising or originating from failure of defective parts will be home by the Buyer.

The requirements for sign content are determined by intended use and by applicable regulation. BUYER is responsible for determining the appropriate content for a sign. ComplianceSigns.com makes no warranty or representation of suitability of a sign for any specific application.

Compliance Guarantee:

Our Compliance Guarantee lets you order regulatory signs with confidence. If you order a sign you think will pass inspection and learn within six months that you have the wrong sign, we'll give you full credit toward purchase of a correct sign. Contact our Sales Department for details and return information.